OPERATION MANUAL

ASPHALT AND CONCRETE CUTTERS



SEAFLOOR 500S

Congratulations! You have purchased an asphalt and concrete cutter SEA Technology. You receive high-quality and powerful machine, intended for professional use under the heaviest conditions.

Read carefully this operation manual before starting the machine and always keep the instruction - this way you will secure safe operation, high working output and long durability of the machine.

The manufacturer bears no responsibility for damages arising from not keeping the operation manual.

This machine was manufactured by SEA Technology Srl.

Address: **SEA Technology Srl**

Via Meucci 1, 42028 Poviglio, RE

info@seatechnology.eu

0522 966102



SEA Technology Srl. is a light construction equipment manufacturer with a long-term experience. SEA Technology machines are exported to many European countries, among others to Spain, Netherlands, Italy, Hungary, Romania and Russia.

SEA Technology has certified quality control system according to ISO 9001:2008.

All manufactured models undergo testing, measuring and consideration of safety risks; all machines conform to safety standards and bear the CE mark.

CONTENT:

1.	SAFETY INSTRUCTIONS	5
1.1.	GENERAL INSTRUCTIONS FOR OPERATION OF LIGHT CONSTRUCTION EQUIPMENT	5
1.1.1.	<i>Requirements for qualification of the operator</i>	5
1.1.2.	<i>Contractor's obligations</i>	5
1.1.3.	<i>Operator's obligations</i>	5
1.1.4.	<i>Operation of the machine</i>	5
1.1.5.	<i>Maintenance and Service.....</i>	6
1.1.6.	<i>Transport and Storage.....</i>	6
1.2.	PROHIBITED ACTIVITIES	7
1.3.	HYGIENIC PRINCIPLES.....	7
1.4.	ENVIRONMENTAL PRINCIPLES.....	7
1.5.	LIQUIDATION OF THE MACHINE	8
1.6.	SAFETY INSTRUCTIONS.....	8
1.7.	HYGIENIC DATA	8
1.8.	LIST OF SAFETY MARKS USED ON THE MACHINE	9
1.9.	DISPOSE OF PACKING MATERIAL.....	10
2.	TECHNICAL DESCRIPTION	10
2.1.	BASIC TECHNICAL DATA:	11
2.2.	LUBRICANTS	12
2.3.	IDENTIFICATION.....	13
2.4.	ENGINE IDENTIFICATION	13

3. PRIOR TO STARTING 13

3.1. CHECK - OIL LEVEL.....13

3.2. VISUAL INSPECTION OF THE MACHINE14

3.3. ADDING FUEL.....14

3.4. CHECK - AIR FILTER.....14

3.5. TIPPING MACHINE.....15

4. OPERATION 15

4.1. STARTING15

 4.1.1. Gasoline Engines HONDA.....15

4.2. OPERATION16

 4.2.1. Selection of the Cutting Disc.....16

 4.2.2. Fastening of the Cutting Disc.....16

 4.2.3. Cutting.....16

 4.2.4. Cutting Depth Scale.....17

4.3. ENGINE TURNING-OFF17

4.4. HANDLING, TRANSPORT, STORING17

 4.4.1. Manual Handling.....17

 4.4.2. Handling by Crane17

 4.4.3. Handling by Forklift.....17

 4.4.4. Transport17

 4.4.5. Storing17

4.5. SPECIAL CONDITIONS OF OPERATION.....17

 4.5.1. Work at Low Temperatures17

 4.5.2. Work at High Altitudes.....18

 4.5.3. Work in Dusty Environment.....18

5. MAINTENANCE 18

5.1. MAINTENANCE OF THE ENGINE.....18

5.2. TENSIONING OF THE DRIVE BELTS18

5.3. INSPECTION OF BOLTED CONNECTIONS19

5.4. ADJUSTMENT OF ENGINE SPEED19

6. MAINTENANCE SCHEDULE 20

7. WARRANTY CONDITIONS..... 21

Revision	Content	Date
1		
2		
3		

1. SAFETY INSTRUCTIONS



1.1. General instructions for operation of light construction equipment

1.1.1. Requirements for qualification of the operator

1. The machine must be operated by trained reliable operators of age above 18. The operator must read and understand the safety instructions, the regulations valid for the respective jobsite and valid technological procedure. This should be proved by getting the operator's signature.
2. The operator is obliged to use suitable working dress, safety gloves and firm boots with hard tip. Do not wear loose or torn clothes, chains or jewelry that could be caught by moving parts of the machine. The operator is obliged to use safety goggles and ear protection.
3. The machine may be used for intended purpose only, in accordance with this operation manual.

1.1.2. Contractor's obligations

The contractor is understood to be a physical or legal person that carries out construction works and for such purpose uses construction equipment. The contractor is responsible for operational safety.

The contractor is obliged to:

- designate the operator and arrange his training
- ensure safe working conditions
- inspect attendance of the safety regulations
- inspect that the operator works with the machine in accordance with the Operation Manual
- ensure regular inspections, maintenance and repairs of the machine
- store the Operation Manual so that it is readily available
- arrange suitable, safe and adequate storing of the machine when not in use

The contractor is also responsible for proper attendance of lawful regulations of work safety and regulations valid for each respective jobsite.

1.1.3. Operator's obligations

The operator is to be designated by the contractor, while keeping conditions of the article 1.1.1.

The operator is namely obliged to:

- prior to starting, he should read and understand the Operation Manual including the safety instructions
- attend all instructions of the Operation Manual
- learn about the jobsite and the locally valid safety regulations; these must be kept during the work
- pay full attention to operation of the machine
- arrange that regular inspections, maintenance and repairs of the machine are carried out as according to the Operation Manual
- require from the contractor proper conditions for keeping safety instructions, regular inspections, maintenance and repairs
- avoid damage, misuse or unauthorized use to the machine, namely by proper storing the machine to a secured place

1.1.4. Operation of the machine

Before starting:

1. Check the machine thoroughly, repair all failures before starting the engine. If the failures cannot be repaired at the jobsite, do not operate the machine.
2. Check the fuel system for leaking. Dripping fuel poses fire hazard.

Starting and operation:

3. When starting the engine, take stable position and held the grip firmly.
4. The controls must be in good order.
5. The operator must not leave from his position when the engine is running.
6. Stop the engine before interrupting the work. When parking the machine, secure it from falling.
7. Stop the engine before refueling. Avoid contact between fuel and hot parts of the engine. Let the engine to cool down first.
8. Keep the fuel tank tightly closed. Close the fuel tap when not in operation. Drain the fuel before transporting the machine for longer distances.



DANGER! Leaking fuel tank and distribution may cause explosion. Replace these parts immediately if damaged.

Jobsite:

9. No bystanders are allowed within the operational range of the machine. Especially children should be kept in safe distance.
10. Do not operate the machine in areas with

explosion danger.

11. If operated in closed spaces (halls, tunnels), there should be ensured sufficient ventilation.



PERICOLO

L'uso di un generatore in casa PUO' UCCIDERTI IN POCHI MINUTI. I gas di scarico del generatore contengono monossido di carbonio. Questo è un veleno che non puoi vedere o annusare.

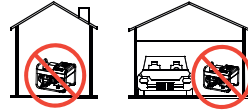

NON usare MAI all'interno di una casa o di un garage. ANCHE SE porte e finestre sono aperte.

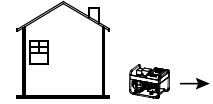

Utilizzare solo ALL'ESTERNO e lontano da finestre, porte e prese d'aria.

12. Held and guide the machine with high care in order to avoid hands injury caused with contact with an obstacle.
14. Do not smoke, do not use naked flame. Do not work close to flammables or in explosion danger areas.
15. Avoid touching hot parts. The exhaust silencer and other parts of the engine are very hot during operation and touching them can cause serious burns.

1.1.5. Maintenance and Service

1. Check the technical condition of the machine regularly, mainly the protective and operation parts. Arrange any possible defects repair.
2. Only qualified personnel is allowed to do service works.
3. Service works should be done only in workshops, where ecological rules and work safety are ensured. If machine needs to be serviced at the job site, make sure not to collide with other machines or equipment. It is prohibited to service the machine at places where ecology, work safety could be endangered, for example by other equipment operation, landslide, etc.
4. Service works can be done only when the engine is switched off. If it is necessary to start the engine, pay attention.
5. Use only genuine spare parts.
6. Any modifications can be done only with manufacturer prior approval.

1.1.6. Transport and Storage

1. Machine can be transported only by vehicles and equipments with corresponding capacity.
2. When using a crane corresponding safety rules must be applied. To be done only by authorized personel.
3. Use the lifting point marked at the machine.
4. When loading by hand cooperation of more people is needed, pay attention to max. allowed carrying capacity of a worker.
5. Secure the machine to prevent damage or overturning.
6. Machine must be transported in upward position.

1.2. Prohibited activities

Never:

- use the machine for other than intended purposes
- use the machine in other way than as described in the Operation Manual
- operate the machine drunk or intoxicated
- operated the machine if its operation could cause harm to other people
- start and operate the machine if there are other people within the dangerous area
- operate the machine if some safety device (i.e. cover) is damaged or missing
- operate the machine in areas with external risks (risk of soil flow, dangerous fumes,risk of explosion, risk of electrical shock,etc.)
- operate the machine in areas where its operation may cause damage to buildings,structures or utility line
- operate the machine within the protective range of power lines or transformer stations
- operate the machine under poor visibility or at night, unless the jobsite is sufficiently illuminated
- leave unprotected machine
- disable or modify safety devices,protective and safety systems
- operate the machine with leaking oil, fuel or other liquids
- start the engine in other way than described in the Operation Manual
- clean a running machine
- smoke or use naked flame when refueling

1.3. Hygienic principles

Oil derivatives (fuel, lubricants) as well as paints and thinners are harmful agents. Anyone who gets into contact with such agents is obliged to protect himself and follow general principles health protection as well as to follow instructions valid for each specific agent.

Pay special care to:

- skin care
- wash hands properly after finishing the work and apply suitable cream

Store the fuels, lubricants, paints, thinners, cleansing and conservation agents, as well as other dangerous agents in original containers, properly sealed. Never allow storing in unmarked bottles or containers or even in beverage bottles. Store such agents in safe place, out of reach of children.

In case that the agent gets into touch with skin or eyes, or when it is eaten or inhaled, apply the first aid and get immediately medical aid.

1.4. Environmental principles

Fuel, lubricants and other operational fluids are harmful to environment. This category also includes part of the machine that get into contact with operational fluids, such as filter and hydraulic hoses.

After use these belong to dangerous waste.

Pay high attention to avoid leakage of the fluids and their escape into soil or water (including the sewage).

Store the fluids in such manner, that the fluids gets caught in case of accidental leakage.

If these agents still escape, arrange their safe collection and liquidation.

1.5. Liquidation of the machine

After the machine exceeds its lifetime period, the contractor is obliged to arrange its proper liquidation in accordance with the respective lawful regulations and with regards to environmental protection.

- Metal parts must be disposed only by authorized companies.

- Used oil must be disposed only by authorized companies.

SEA Technology bears no responsibility for any damages caused by breaking above mentioned hygienical and ecological rules.

1.6. Safety Instructions

Besides of general safety instruction, the following special instruction must be followed:

1. Prior to starting the work, find out where are underground spaces, utility lines, etc.
2. Never remove the blade cover when the engine is running.
3. After stopping the engine, wait till the blade gets fully halted.
4. After fitting the cutting blade, pace on the cover

and secure it.

5. Be sure to remove the wrenches from the blade shaft!
6. Do not allow other people close to running machine.

7.  **DANGER!** The cutting blade is always turning as soon as the engine is started. The revolving blade presents a risk of

1.7. Hygienic data

	SEAFLOOR 500S
Declared noise emission level at the operator L_{pAd} [dB] (Measured according to EN ISO 11201: 2010 and EN 13862 + A1, Annex A idling)	92
Guaranteed sound power level $L_{WA,G}$ [dB] (As measured by NV no. 9/2002 Coll., Annex no. 3, section B, paragraph 31, respectively, in accordance with Directive 2000/14 / ES, Annex III, Part B, item 30 and EN ISO 3744: 2010)	101 +4
Acceleration transferred to hands a_{hvd} [m.sec ⁻²] (Measured according to EN 13862 + A1, Annex F under load and EN ISO 20643)	5,,22 +2,09

Information for users of above mentioned machinery, requested by directives: 2003/10/ES – exposure of operators to noise and 2002/44/ES – exposure of operators to vibrations (czech equivalent NV no. 272/2011 Sb.):

With regard to declared acoustic pressure value A at working place of the operator and to declared aggregate value of hand-arm vibrations transferred to the operator it is necessary to use protective equipment effective against above mentioned noise value and hand-arm vibrations when operating the particular type of the floor saws and further it is necessary to modify the working processes because of setting technological breaks due to reduce the exposure of the operator to the hand-arm vibrations.

Exposure can be mutually proportional to the mass operator.

ATTENTION!







The noise emission measurements obtained in accordance with the European standards do not necessarily correspond with varying levels of noise produced under process real conditions of use. Measurements are made when the machine is running on empty - no load.

In case of casting machines suitable blade can also cut dry. Due to an increased incidence of dust, but in this case you must use protective equipment for respiratory protection (respirator).

1.8. List of safety marks used on the machine

In accordance to requirements of law no 22/1997 Sb. About technical requirements on products in valid version, there are stickers of safety marks and informative symbols placed on the machines (types – see point 2.1). Types of the stickers are explained further, explanation is attached to each symbol.

<p>1. Combined stickers of safety symbols according to ČSN ISO 3864 (symbol no. B.2.5, B.3.1 and NB. 2.26), symbol according to CS ISO 6405-1 (symbol no, 7.28) and information for operating the machine. Safety symbol no. B.2.5 orders the operator to use ear protection. Symbol no. 7.28 orders the operator to read the manual prior to starting the operation. Safety mark, symbol no. NB.2.26 orders the operator to use protective gloves during the operation to reduce vibrations. Safety mark, symbol no. B.3.1 (exclamation mark) warns the operator from the danger risk. Information for the operator regarding repair, cleaning or adjusting the machine.</p>	
<p>2. Symbol no. 7.23 according to CSN ISO 6405-01 (sticker shows spots which should be greased according to operation manual)</p>	
<p>3. Symbol no. 8.1 according to CSN ISO 6405-01 (sticker show spot where engine oil drain bolt is located)</p>	
<p>4. Safety symbol no. B.3.1 (exclamation mark) warns the operator from danger risk. Symbol shows blade and the shoe, which means: PAY ATTENTION FOR LEG INJURY FROM ROTATING CUTTING BLADE.</p>	
<p>5. Symbol no. 7.25 according to CSN ISO 6405-01 (symbol shows machine lifting points)</p>	



La benzina è estremamente infiammabile ed esplosiva. Spegnerne il motore e lasciarlo raffreddare prima di effettuare il rifornimento.







Leggere il manuale d'uso prima di azionarlo del motore HONDA GX390.

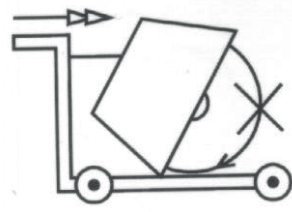

Il motore rilascia monossido di carbonio che è un gas tossico velenoso. Non azionare in un luogo chiuso.

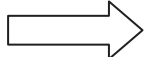

6.	Sticker with information that the machine can't be transported with running cutting blade.	
7.	Sticker with information of fuel type	
8.	Sticker BLACK ARROW (shows blade turning direction)	
4.	Sticker WHITE ARROW (shows blade setting against cut material at the depth scale).	
10.	Sticker showing the depth scale	
11.	Sticker showing the noise value which was measured by test according to conditions NV no.9/2002 in machines (types – see point 2.1). The value is only informative, it differs for each machine type.	

2. TECHNICAL DESCRIPTION

The asphalt and concrete cutters SEAFLOOR 500S are intended for cutting of asphalt and concrete floors or road layers when repairing roads, industrial areas, etc.

The machine is based on a rigid frame with fixed spindle; the cutting disc is lowered to the cut together with the whole frame. Lowering and rising of the cutting disc is controlled by means of a arrested handle that enables fine regulation of cutting depth.

The machine is intended for wet cutting and therefore it is equipped with a sprinkling system. Water for sprinkling can be brought either from machines-mounted water tank or from external source.

The machines can be used also for dry cutting, assuming a suitable cutting disc is used. This method however causes high generation of dust and thus breathing protection would be required.

The machine is driven by a single-cylinder, four-stroke gasoline engine HONDA.

Travel is manual; the operator pushes the machines by height-adjustable handle.

Floor saws SEAFLOOR 500S are equipped with a reference depth scale.

2.1. Basic Technical Data:

		SEAFLOOR 500S
Cutting depth	(mm)	200
Cutting disc fastening		at right
Max. disc dia	(mm)	500
Travel		manual
Cutting depth adjust.		mechanical, adjustable
Fastening hole dia	(mm)	25,4
Spindle speed	(RPM)	2800
Water tank capacity	(ltr)	15
Water supply		aqua clutch
Weight (waterless)	(kg)	110
Dimensions L x W x H	(mm)	1060x550x960
Engine		HONDA GX390
Nominal power	(kW)	*8,7
Max. speed	(RPM)	3600
Oil sensor		yes
Fuel consumption	(ltr/hr)	3,5

- *Engine output is mentioned according to SAE 1349

- **Engine output is mentioned according to SAE 1940

Actual output of the engine installed in the machine can be different with regard to various factors, such as operation speed of the engine, operation conditions, maintenance and other factors.

Engine operation speed is not identical with engine rated speed and this is set according to technical parameters of the machine.

2.2. Lubricants

For use in both engine use high-quality engine oils of the following specifications: 10W-30 API SJ/CF
- engine oil

HONDA GX270	approx. 1,1 ltr
HONDA GX390	approx. 1,1 ltr
BRIGGS STRATTON 1450 SERIES	approx.. 1,1 ltr
BRIGGS STRATTON 2100 SERIES	approx.. 1,1 ltr
SUBARU EX 27	approx. 1,0 ltr
SUBARU EX 40	approx. 1,2 ltr

Alternatively other quality oils of class SAE 10W-40 of classification API SG/CF 4, API SG/CE can be used.

2.3. Identification

For communication with the manufacturer (i.e. for warranty claims, service requests, spare parts ordering) always report exact model and serial number of your machine.

These data are stamped on the machine decal.

Fig. Machine decal



2.4. Engine Identification

In case of problems related to the engine report also engine type and serial number. This number is stamped on the engine block (HONDA) If you have doubts, contact the manufacturer.

Fig. Location of the S/N on engine HONDA



3. PRIOR TO STARTING

- Check whether the engine leaking (leaks) oil. In case of defect, contact an authorized service center or manufacturer.
- Bolted connections for loop control of depth of cut and the matrix arm guidance (SS 120, 170) are glued. Screws at the pulleys, the drive chassis are tight and prescribed the query moment. We therefore recommend against any potential activity associated with permitting and tightening of joints, and contact information to an authorized service center or manufacturer.

3.1. Check - Oil Level

It is highly recommended to check regularly the engine oil level even at machines equipped with the oil sensor. In case of a machine without the oil sensor, daily check is a must.

Clean the filling hole before checking or adding oil. Wipe dry the dipstick and immerse it in the oil without screwing it in.

If necessary, add specified sort of oil up to the upper mark.

NOTE :

Operation with insufficient oil level may cause serious damage to the engine.

Oil level checking procedure:

Have the machine at even surface. Remove the filler cap, the oil comes out of the drain hole slightly when the oil level is correct.

Check the engine oil level daily!

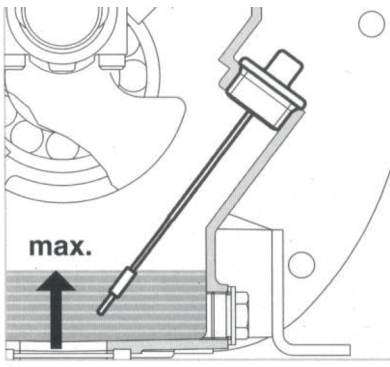

3.2. Visual Inspection of the Machine

Check regularly the machine for:

- missing parts
- released bolts and screws
- oil or fuel leakage

- free motion of the cutting disc spindle

Pay special attention to safety devices (covers) and controls.

3.3. Adding Fuel

1. Gasoline engines:

Use unleaded or leaded gasoline for motor vehicles, with octane number 91 or more.

Top up fuel as necessary.

Never use dirty fuel or mixture with oil.

Avoid water and dust from entering the fuel tank.

3.4. Check - Air Filter

Check the air filter for cleanness on a daily basis. Clean or replace the filter if dirty.

Never run the machine with air filter missing or damaged. Dust and dirt which get into the engine would cause rapid wear.

Fig. Air filter - HONDA

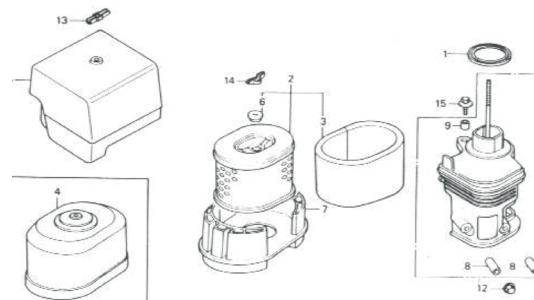

Air filter - **BRIGGS & STRATTON**

Air filter - **SUBARU**

3.5. Tipping machine

Tipping machine when the machine tipped over may break of oil into the carburetor, or the plunger. Therefore, we recommend to inform the authorized service center, or the manufacturer about how to proceed.

4. OPERATION

4.1. Starting

4.1.1. Gasoline Engines HONDA

1. Turn the fuel tap into the ON position.

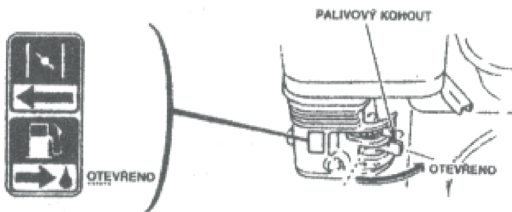

2. Turn on the electric switch of ignition.

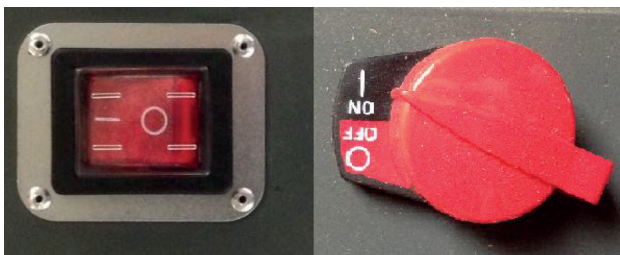

3. Engage the choke („CHOKE“). Do not use it at warm engine or at high ambient temperature.

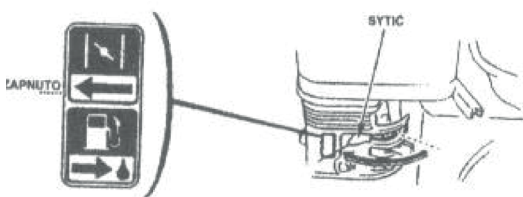

1. Adjust the throttle control lever to idle.



5. Pull out the starter grip slowly till some resistance is felt, then pull vehemently. Do not release the grip, but return it slowly into the original position.
6. Let the engine to warm up, then disengage the choke.
7. Let the engine to run at idle for a while before loading.
8. For cutting, shift the throttle control lever to fully open position.

DANGER!

The spindle and the cutting disc begins to rotate immediately. Be sure that the revolving disc would not cause any danger for the bystanders. Have the disc cover closed before starting. When using SUBARU engine, proceed according to SUBARU engine manual.



4.2. Operation

4.2.1. Selection of the Cutting Disc

For safe and efficient operation, right selection of the cutting disc is highly important. Choose a high-quality diamond cutting disc and appropriate type depending on the material to be cut (asphalt, concrete).

Cutting discs of most suppliers are divided in quality categories (standard/profi etc.), sometimes also according to length and height of the diamond

segments, spacing, etc.

Cutting disc diameter is to be selected according to the type of the machine; if possible, choose always the maximal allowed diameter (SEAFLOOR 500S 120 350 mm, SEAFLOOR 500S 170 450 mm). The spindle speed is adjusted for this size to keep optimal circumferential cutting speed of the disc.

4.2.2. Fastening of the Cutting Disc

1. Turn off the engine and open the disc cover.
2. Use the enclosed wrenches to hold the spindle and unscrew the fastening nut.

NOTE: Left thread!

3. Fit the cutting disc on the spindle and secure it.
4. Close the disc cover and secure it.



4.2.3. Cutting

1. Have the disc raised above floor. Start the engine and set full throttle.
2. Open the water tap to engage sprinkling.
3. Move the machine to the beginning of the cut.
4. Lower slowly the disc into the cut, till required cutting depth is reached.
5. Sensitively push the machine forward and follow the marked path (use the guide).
6. The machine can only cut in straight direction. In case the direction must be changed, raise the

disc from the cut, take new direction and lower the disc again.

7. At the end of the cut, raise the disc, set the throttle to idle.

NOTE! The cutting disc should be sprinkled all the time. Follow the water level in the tank and timely add water as necessary. Dry cutting may cause fast damage to the disc.

For optimal service life of the cutting disc, the operator should work carefully and sensitively. Do not force the machine!

Nevertheless, lifetime of the disc may vary depending on the material to be cut and other factors.

4.2.4. Cutting Depth Scale

Cutters SEAFLOOR 500S 120, SEAFLOOR 500S 170 and SEAFLOOR 500S200 have just informative

cutting depth scale. Turning the handle for 360 degrees lowers the blade for about 15 mm.

4.3. Engine Turning-Off

1. Shift the throttle control lever to idle position. (see point 4.1.1.4).
2. Let the engine to idle for a while to cool down.
3. Turn the ignition switch to "OFF".
4. Close the fuel tap

4.4. Handling, Transport, Storing

When handling the machine keep safety regulation shown in this manual and well as general safety rules

valid for operation of lifting or hoisting equipment.

4.4.1. Manual Handling

For manual lifting, cooperation of mode people is required. Hold the machine by frame or the base

plate. Never lift the machine by engine.

4.4.2. Handling by Crane

Use a crane of sufficient payload (see Technical Data). Observe the regulations valid for operation of cranes. Only qualified personnel may carry out this work.

Fasten the lifting cable to the marked point at the machine.

4.4.3. Handling by Forklift

Should be the machine extensively handled by a forklift (as when sending it by a parcel service), it is recommended to palletize it. For one machine

use "small" palette (0,8x0,6m), for two machines standard EUR pallet (1,2x0,8m).

4.4.4. Transport

Secure the machine against rolling over, falling down or sliding on the carrier. Fasten the binding means to suitable points at the frame.

NOTE:

The machine must be kept in upright position. If overturning happens, see point 3.5.

4.4.5. Storing

Store the machine on a safe place, secured from theft and misuse. We recommend an indoor dry place, without excessive concentration of chemical agents and dust.

Prior to long-term storing clean the machine, repair the paint and apply suitable preservation agents. Mark visibly that the machine has been conserved.

4.5. Special Conditions of Operation

4.5.1. Work at Low Temperatures

The cutter is able to work even at low temperatures. Let the engine to warm up sufficiently before commencing the work.

In case that the machine is difficult to start, let it warm up at room temperature first.

4.5.2. Work at High Altitudes

With rising altitude the engine power decreases due to changed air/fuel ratio. The engine power can be partially improved by changing of the main nozzle and different adjustment of the carburetor.

In case that the engine should work long-term above

1500 m above seal level, we recommend to contact a nearest authorized service for the respective engine.

In case that you plan this kind of operation already when purchasing a new machine, notify the manufacturer.

4.5.3. Work in Dusty Environment

In case of dusty environment shorten the cleaning/ replacement intervals of the air filter to half.

Clean the machine from dust regularly.

PERICOLO

Gas di scarico velenosi



I gas di scarico del motore a combustione contengono monossido di carbonio. È un gas invisibile, inodore e insapore che può causare perdita di coscienza e soffocamento. Può accumularsi rapidamente nei locali chiusi e rimanervi per ore, anche dopo che il motore è stato spento.

- Non utilizzare mai macchine con motori a combustione in spazi chiusi o confinati.
- In caso di nausea o malessere, spegnere immediatamente il motore e cercare aria fresca. Consultare un medico. Si potrebbe soffrire di avvelenamento da monossido di carbonio.
- Per maggiori dettagli fare riferimento al manuale d'uso del produttore del motore, fornito insieme al presente manuale.



Il motore rilascia monossido di carbonio che è un gas tossico velenoso. Non azionare in un luogo chiuso o confinato.

PERICOLO

L'uso di un generatore in casa PUO' UCCIDERTI IN POCHI MINUTI. I gas di scarico del generatore contengono monossido di carbonio. Questo è un veleno che non puoi vedere o annusare.

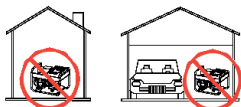

NON usare MAI all'interno di una casa o di un garage. ANCHE SE porte e finestre sono aperte.

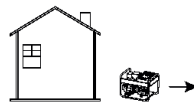

Utilizzare solo ALL'ESTERNO e lontano da finestre, porte e prese d'aria.

5. MAINTENANCE

The basic activities of maintenance, which are described in this Manual can be carried out by the designated operator.

Repairs and adjustments beyond the extent of this Manual should be committed to an authorized service. It is forbidden to intervent the engine (except for standart maintenance) during warranty period.

Bolted connections to the loop control of depth of cut and the matrix arm of instruction (at SEAFLOOR 500S 120, 170) are glued. Screw with a pulley, the drive chassis are tight and prescribed the query moment .. We therefore recommend against any potential activity associated with permitting and tightening of joints, and contact information to an authorized service center or manufacturer.

5.1. Inspection of Bolted Connections

It is recommended to inspect the bolted connections daily before work.

5.2. Adjustment of Engine Speed

In case of engine replacement or repair it is necessary to adjust engine speed.

Speed is measured by a digital tachometer.

Therefore, the speed setting is recommended to entrust a qualified serviceman.

5.3. Tensioning of the Drive Belts

Check regularly tensioning of the drive belts that drive the cutting disc. Deflection of the belts under finger pressure should be about 5 mm.

To tension the belts, proceed as follows:

- loosen 4 bolts which fasten the engine to the base plate
- turn the tensioning screw to tension the belts
- re-tighten the fastening bolts

When replacing the belts, use all belts of the same type and dimension.

NOTE! Do not over-tension the belts!

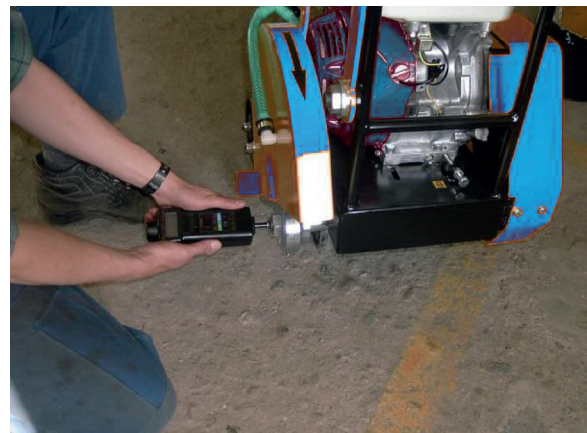

6. MAINTENANCE SCHEDULE

This maintenance schedule contains only the most important operations. Besides of these operations, carry out maintenance and repairs of the machine as necessary depending on the respective conditions of operation. Check also the engine operation manual.

WARNING:

Turn off the engine before any maintenance or repair activity.

Use genuine spare parts only. Use of non-original spare parts may lead to damage to the machine. The manufacturer will not honor any warranty claim arising from such reason.

Item	Operation	Initial inspection	After 1st month or 20 hrs.	Every 3 months or 50 hrs.	Every 6 months or 100 hrs.
Engine oil	Inspection of oil level	<input checked="" type="checkbox"/>	DAILY		
	Exchange		<input checked="" type="checkbox"/>		<input checked="" type="checkbox"/>
Air filter	Inspection	<input checked="" type="checkbox"/>			
	Cleaning		<input checked="" type="checkbox"/> (1)		
Spark plug (gasoline engines)	Inspection - cleaning				<input checked="" type="checkbox"/>
Cyclone filter	Cleaning			<input checked="" type="checkbox"/> (3)	
Filter bowl	Cleaning				<input checked="" type="checkbox"/>
Fuel hose	Inspection - Exchange	Every two years			
Valve clearance	Inspection - adjustment	Every 12 months or 250 hrs. (2)			
Fuel tank and strainer	Cleaning	Every 12 months or 300 hrs. (2)			
Drive belt	Tensioning		<input checked="" type="checkbox"/>		

- To be carried more often when operating in dusty environment!!!**
- Such maintenance should be performed by service technicians SEA Technology, respectively. authorized service according to engine type, especially if the user does not have the proper tools and knowledge about these devices.**
- In case the engine is equipped by cyclone filter.**

7. WARRANTY CONDITIONS

Construction machines manufactured by SEA Technology are designed and manufactured to suit longterm operation by most difficult conditions. Based on our experience we can say that these machines do work reliably not during the warranty period but also long time after the warranty expires.

If it happens that the machine does not work to your satisfaction, we are always here to help. In case of any failure please proceed as following:

1. Check if the failure isn't caused by breaking operation manual or if it isn't caused by a basic cause (not enough fuel in the tank, low level of engine oil, dirty air filter).
2. If you were unable to fix the failure, contact the manufacturer or its authorized service (see warranty protocol).
3. Mention following info there:
 - Company name, your name, phone and fax number
 - Machine type, serial number
 - Type of failureIf the machine is in warranty, write date of purchase and let the serviceman know it is a warranty case
4. Warranty claim needs to be done in written form, best if Warranty claim form is used.
5. Every warranty claim will be checked by authorized staff immediately and the way of repair will be suggested.

Warranty conditions are described in the agreement with particular distributor.

- The right for warranty expires in following cases:
 - Machine was not used and maintained according to operation manual or was damaged by inadequate intervention by operator or unauthorised service
 - Machine was not serviced according to maintenance plan in operation manual
 - Machine was used in different conditions or for different purpose than it is determined to
 - Other refills or spare parts than recommended were used for repair or maintenance
 - Machine had an accident or was damaged by force majeure
 - Intervention to the machine construction was done without manufacturer approval
 - Failures were caused by inadequate storing or manipulation
 - Items of common wear such as drive belts, bowdells, filters, plastic washers, blades, etc. are excluded from warranty

SEA Technology Spa

Via Meucci 1, 42028 Poviglio, RE

info@seatechnology.eu

0522 966102

Warranty protocol

Number:

(to be filled by warranty dept.)

Failure description (to be filled by machine operator):

Machine type:		Serial number:	
Detailed failure description:			
Is the machine capable of operation?	YES*	NO*	
Date of failure occurring:		Date of failure reporting:	
Machine sale date:		Machine purchased from: SEA Technology / dealer*	Dealer:
Machine owner: (address, phone no., contact person)			
Machine operation site: (if different from owner's address)			

Please send properly filled protocol by fax, e-mail or post to above mentioned address, you will speed the process up!

Accepting the warranty (to be filled in by warranty dept. of SEA Technology):

Date of repair start:		Date of repair finish:	
Internal no:		Signature:	

Claimed failure remedy (to be filled by SEA Technology production dept.):

Way of repairing the failure:	Repair by the user	Repair by SEA Technology	Further way (sending spare parts)
Description of repairing the failure:			
Warranty claim assessment:	YES/NO*	Reason:	
Used spare parts:	Part no.	Description	Pcs

Tech. director sign. :

Production director sign:

Finishing warranty management (to be filled by warranty dept. of SEA Technology):

Returning the machine to owner (in case of repair in SEA Technology):	Arranged by:	Way of transport:	Shipment date:
Warranty extension:	Amount of days:	Warranty valid to:	
Warranty solution information to owner:	Date:	Name:	Signature:

Repair costs:		Costs charged to supplier:	
		Final repair costs:	

EC Declaration of Conformity (original)

We declare that the trough below mentioned specifications defined equipment complies with requirements of below cited Directives

Manufacturer:	SEA Technology Srl P.IVA 02430900353
Identification number:	63221152
Person in charge of assembling and storing technical documentation	SEA Technology Spa Via Meucci 1, 42028 Poviglio, RE
Model:	FLOOR SAW
Type:	SEAFLOOR 500S
Serial number	
Description	Asphalt and concrete cutters are designed for cutting of joints in asphalt or concrete surfaces, i.e. at repairs of roads, industrial areas, etc. The machine is driven with four-stroke single-cylinder engine HONDA, (net power GX270 – 6,3 kW / GX390 - 8,72kW), BRIGGS and STRATTON (net power 1450 SERIES – 7,3 kW / 2100 SERIES - 9,1kW), SUBARU (net power EX27 – 5,1 kW / 7 kW).
The product meets all relevent provisions	Machinery Directive 2006/42/EC Noise Emission 2000/14/EC Electromagnetic Compatibility Directive 2014/30/EU
Harmonised technical standards:	ČSN EN ISO 12100, ČSN EN ISO 13862+A1 EN ISO 14982:2009
Measured sound power level	L_{WA} = SEAFLOOR 500S - 101 dB
Guaranteed sound power level	L_{WAG}= SEAFLOOR 500S - 105 dB

Note: All regulations were applied in wording of later amendments and modifications valid at the time of this declaration issue without any citation of them.

Place and date of issue:
Poviglio, 01/03/2025

Signed by the person entitled do deal in the name of producer:

Name:
Dott. Mirco Dall'Olio

Grade
Presidente e AD

Signature

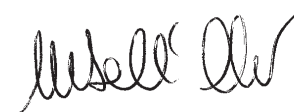

00_Floor saw

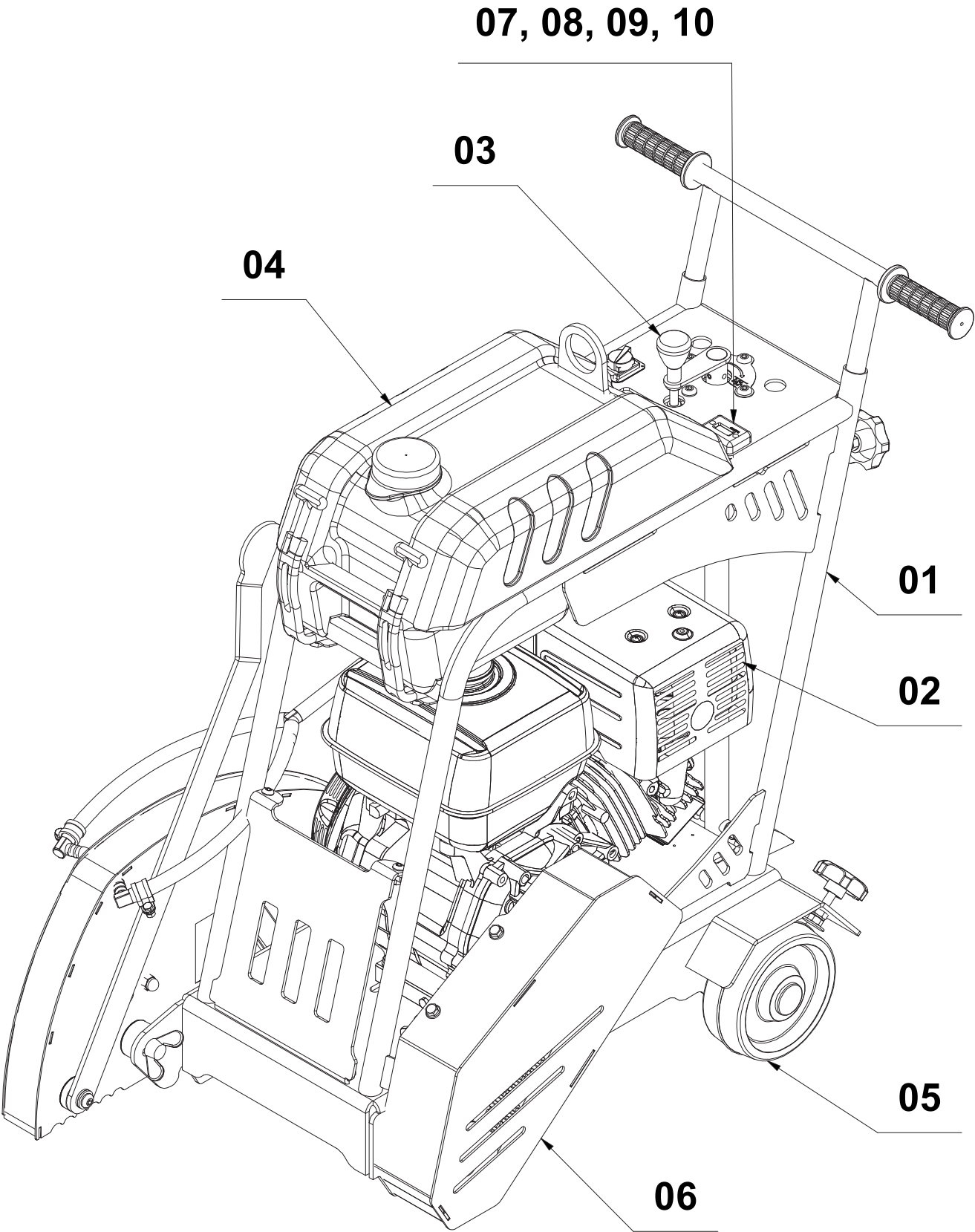

Floor saw
SEAFLOOR 500S

00_Floor saw

Position	Part number	Part Name	Quantity
01	20371B	FRAME	1
02	20379B	DRIVE	1
03	31998A	CONTROL	1
04	32000A	COOLING	1
05	31971B	UNDERCARRIAGE	1
06	32026A	COVER	1

Accessories

07	SF500S6000000296	HOUR METER	1
08	SF500S2912003010	BOLT	2
09	SF500S2934000003	NUT	2
10	SF500S2125000032	WASHER	2

MOUNT OF THE SWITCH FOR BRIGGS AND STRATTON ENGINE

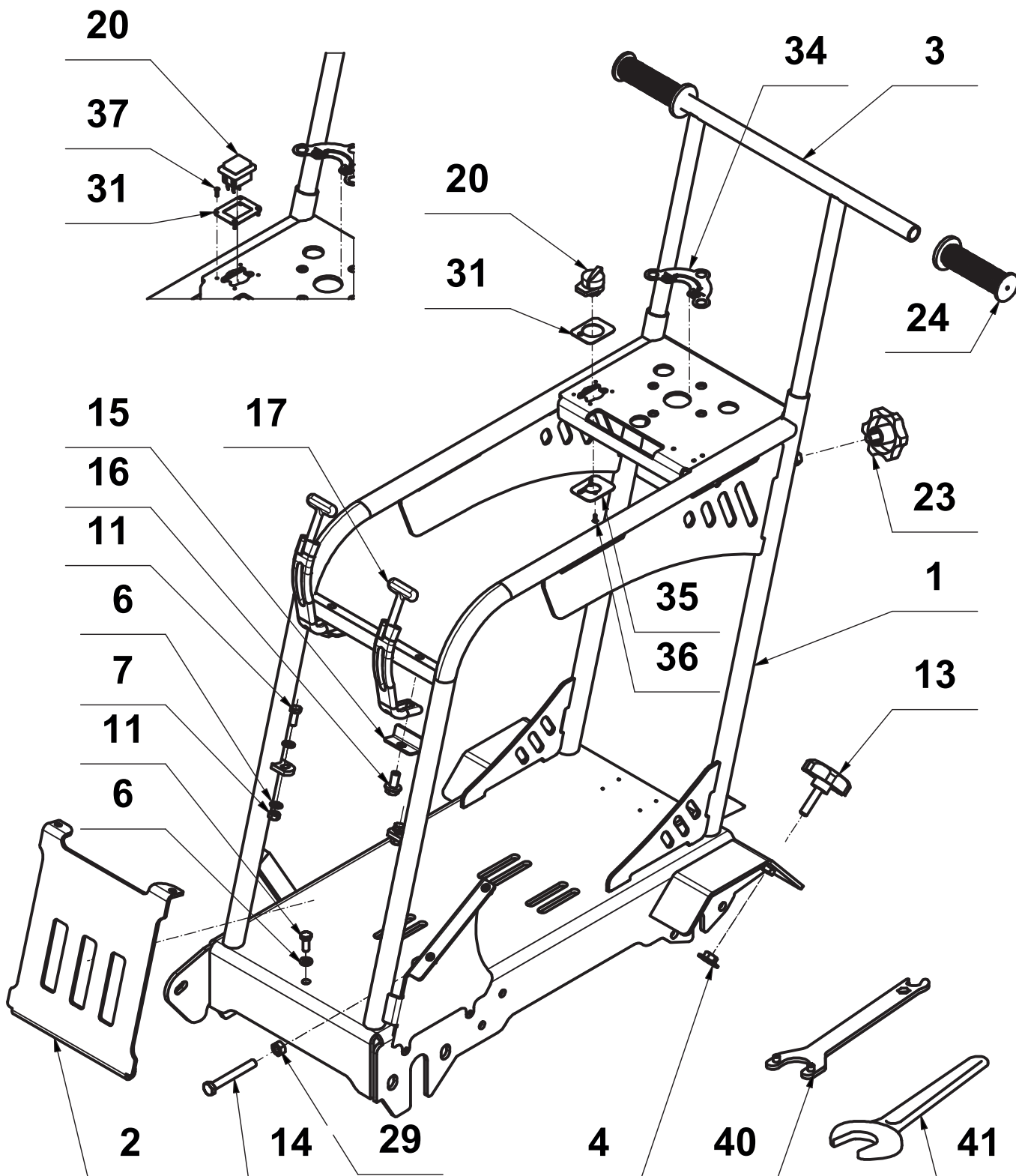

Floor saw
SEAFLOOR 500S

Position	Part number	Part Name	Quantity
1	SF500S20372B	FRAME	1
2	SF500S31988A	COVER	1
3	SF500S31980A	HANDLEBARS	1
4	SF500S42318A	BRAKE PAD	1
6	SF500S2125000084	WASHER	5
7	SF500S2934000008	NUT	2
11	SF500S2933008020	BOLT	3
13	SF500S4260000211	BOLT	1
14	SF500S2933010080	BOLT	1
15	SF500S42281A	TENSIONER HOLDER	2
16	SF500S2738010020	BOLT	2
17	SF500S4200785018	TENSIONER	2
20	SF500S6000000036	SWITCH B&S	1
23	SF500S4260015210	BOLT	2
24	SF500S4014014013	HANDLE	2
29	SF500S2934000010	NUT	1
31	SF500S42351A	COVER	1
34	SF500S42571A	LABEL	1
35	SF500S42284A	SWITCH HOLDER	1
36	SF500S2798129095	BOLT	2

41	SF500S7640000030	SPANNER	1
40	SF500S32213A	SPANNER	1

02_Drive

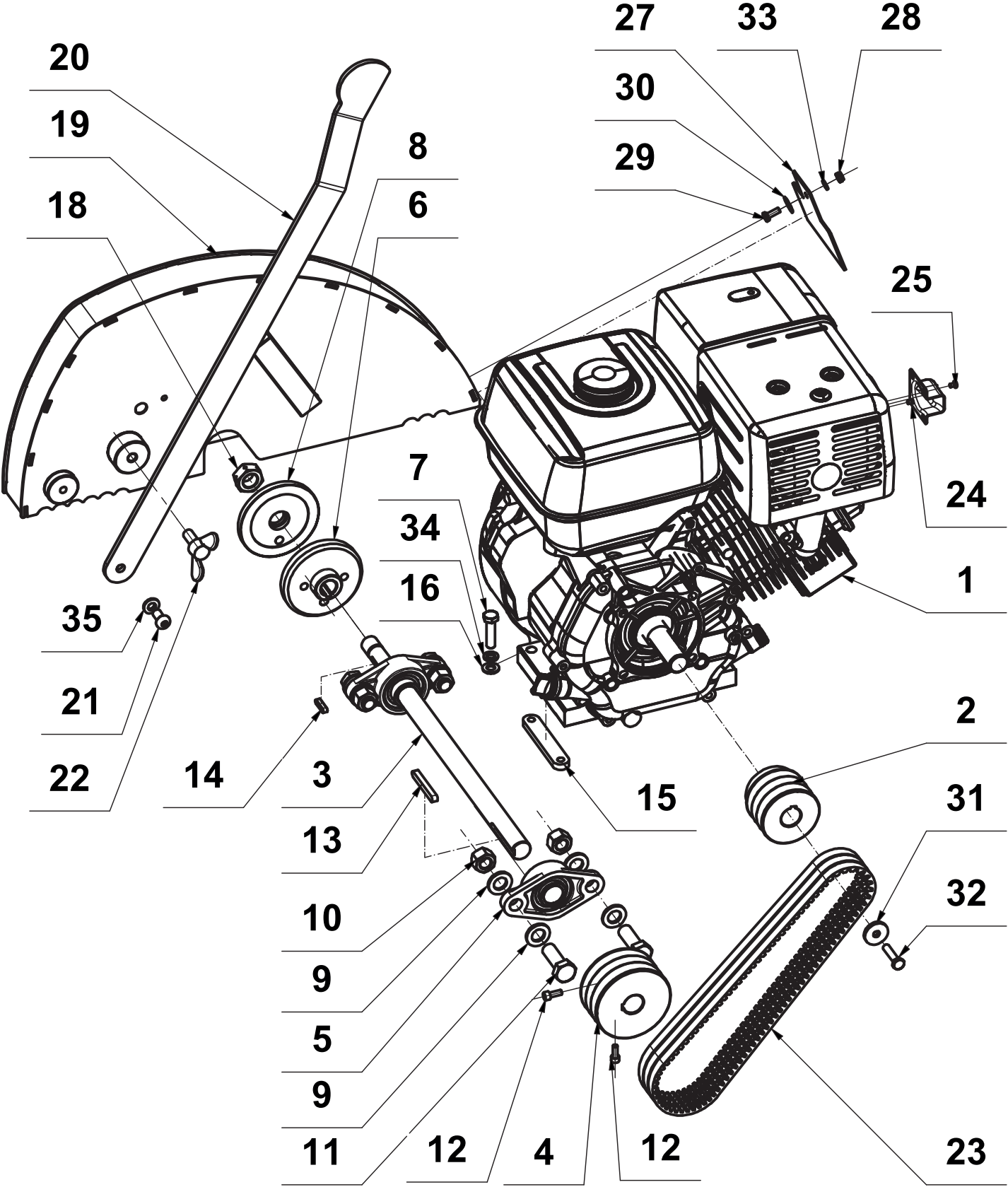

Floor saw
SEAFLOOR 500S

02_Drive

Position	Part number	Part Name	Quantity
1	SF500S3120010053	ENGINE HONDA GX 390	1
2	SF500S32009A	PULLEY	1
3	SF500S31735A	SHAFT	1
4	SF500S32008A	PULLEY	1
5	SF500S3110000208	BEARING	2
6	SF500S31658A	FLANGE I	1
7	SF500S2931010045	BOLT	4
8	SF500S42026A	FLANGE II	1
9	SF500S2125000170	WASHER	8
10	SF500S2985000016	NUT	4
11	SF500S2933016045	BOLT	4
12	SF500S2912006016/2	BOLT	4
13	SF500S2256288763	KEY	1
14	SF500S2256286625	KEY	1
15	SF500S42093A	ENGINE MOUNT	2

02_Drive

Position	Part number	Part Name	Quantity
16	SF500S2125000105	WASHER	
18	SF500S42028A	NUT	
19	SF500S32121A	DISC COVER	
20	SF500S42332A	CUT RULER	
21	SF500S2738010020	BOLT	
22	SF500S2316012030	BOLT	
23	SF500S4080130875	V-BELT	
24	SF500S41061A	EXHAUST DEFLECTOR	
25	SF500S2798504006	BOLT	
27	SF500S600042374A	SHADE	
28	SF500S2985000006	NUT	
29	SF500S2933006016	BOLT	
30	SF500S2902100006	WASHER	
31	SF500S40172A	WASHER	
32	SF500S2933008035	BOLT	
33	SF500S2125000064	WASHER	
34	SF500S2127000010	WASHER	
35	SF500S2209300000	WASHER	
7	SF500S2931010045	BOLT	

02_Drive

Honda Engine Accessories:

Position	Part number	Part Name	Quantity	Note
1	SF500S3126070313	Air filter	1	SEAFLOOR500S Engine GX 390
2	SF500S3126070208	Spark plug	1	

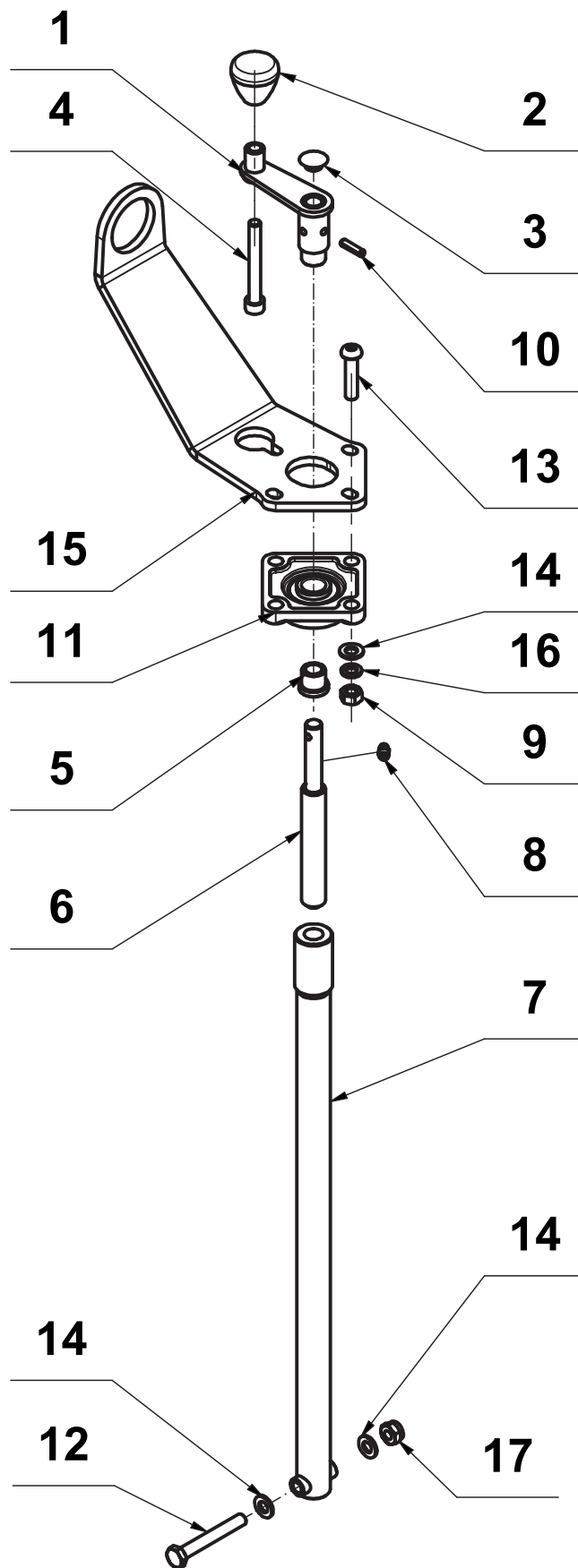

Floor saw
SEAFLOOR 500S

Position	Part number	Part Name	Quantity
1	SF500S42103A	LEVER CONTROL	
2	SF500S4260004010	KNOB	
3	SF500S4014085038	PLUG	
4	SF500S2912010080	BOLT	
5	SF500S42120A	HOUSING	
6	SF500S42121A	CONTROL BOLT	
7	SF500S31999A	TUBE	
8	SF500S3742100801	LUBRICATOR	
9	SF500S2934000010	NUT	
10	SF500S2148106026	PIN	
11	SF500S3110000207	BEARING	
12	SF500S2931010075	BOLT	
13	SF500S2738010040	BOLT	
14	SF500S2125000105	WASHER	
15	SF500S31987A	WASHER	
16	SF500S2127000010	WASHER	
17	SF500S2985000010	NUT	

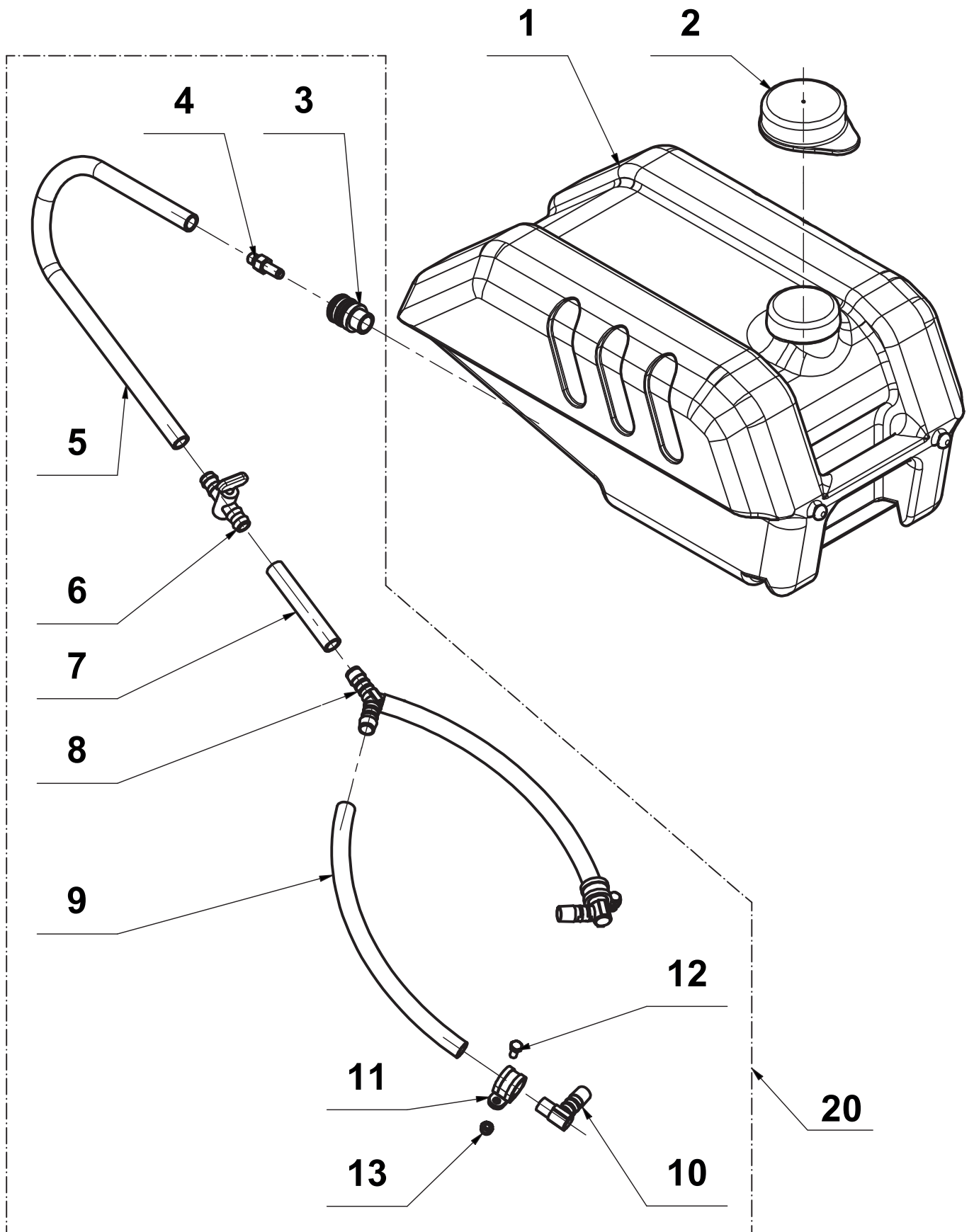

Floor saw
SEAFLOOR 500S

Position	Part number	Part Name	Quantity
1	SF500S600032027A	WATER TANK	1
2	SF500S600031858A	TANK LID	1
3	SF500S3815232005	QUICK COUPLER	1
4	SF500S3815232503	COUPLING PIECE	1
5	SF500S4016001400	HOSE	1
6	SF500S4014435001	WATER TAP	1
7	SF500S4016001400	HOSE	1
8	SF500S4014014011	SOCKET	1
9	SF500S4016001400	HOSE	2
10	SF500S40213AA	SOCKET	2
11	SF500S3651002015	CLASP	2
12	SF500S2933006012	BOLT	2
13	SF500S2985000006	NUT	2
20	SF500S32039A	WATER DISTRIBUTION	1

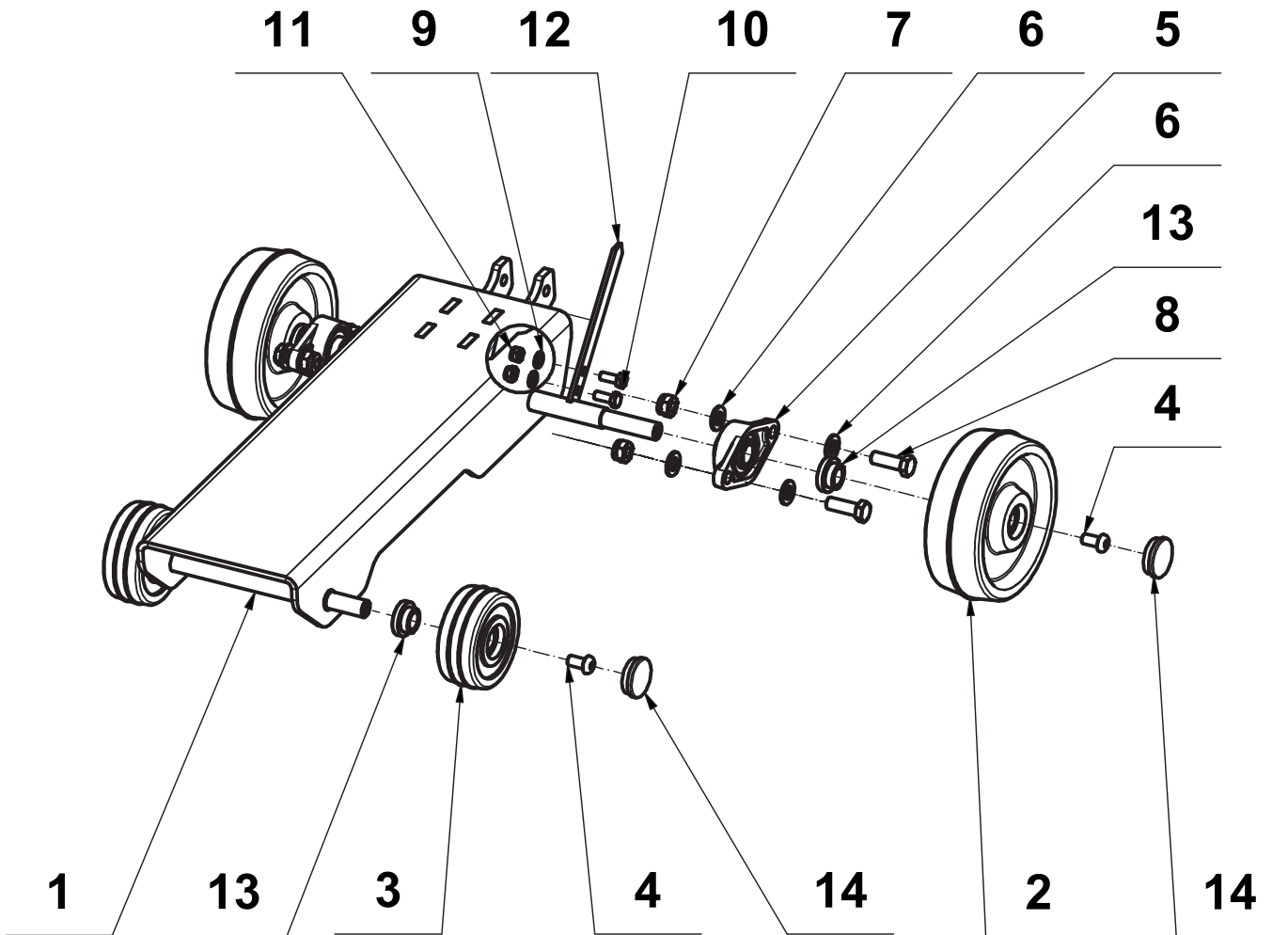

Floor saw
SEAFLOOR 500S

Position	Part number	Part Name	Quantity
1	SF500S31970A	UNDERCARRIAGE	1
2	SF500S32409A	REAR WHEEL	2
3	SF500S32410A	FRONT WHEEL	2
4	SF500S2738010020	BOLT	4
5	SF500S3110000209	BEARING	2
6	SF500S2125000130	WASHER	8
7	SF500S2985000012	NUT	4
8	SF500S2933012035	BOLT	4
9	SF500S2125000084	WASHER	2
10	SF500S2933008020	BOLT	2
11	SF500S2985000008	NUT	2
12	SF500S42283A	INDICATOR	1
13	SF500S42626A	HOUSING	4
14	SF500S4014085043	PLUG	4

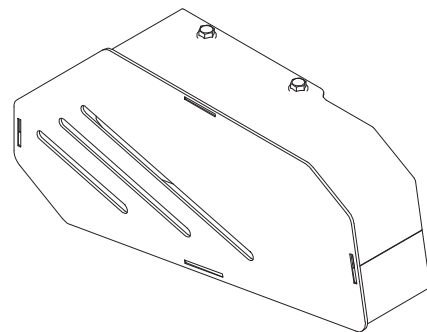
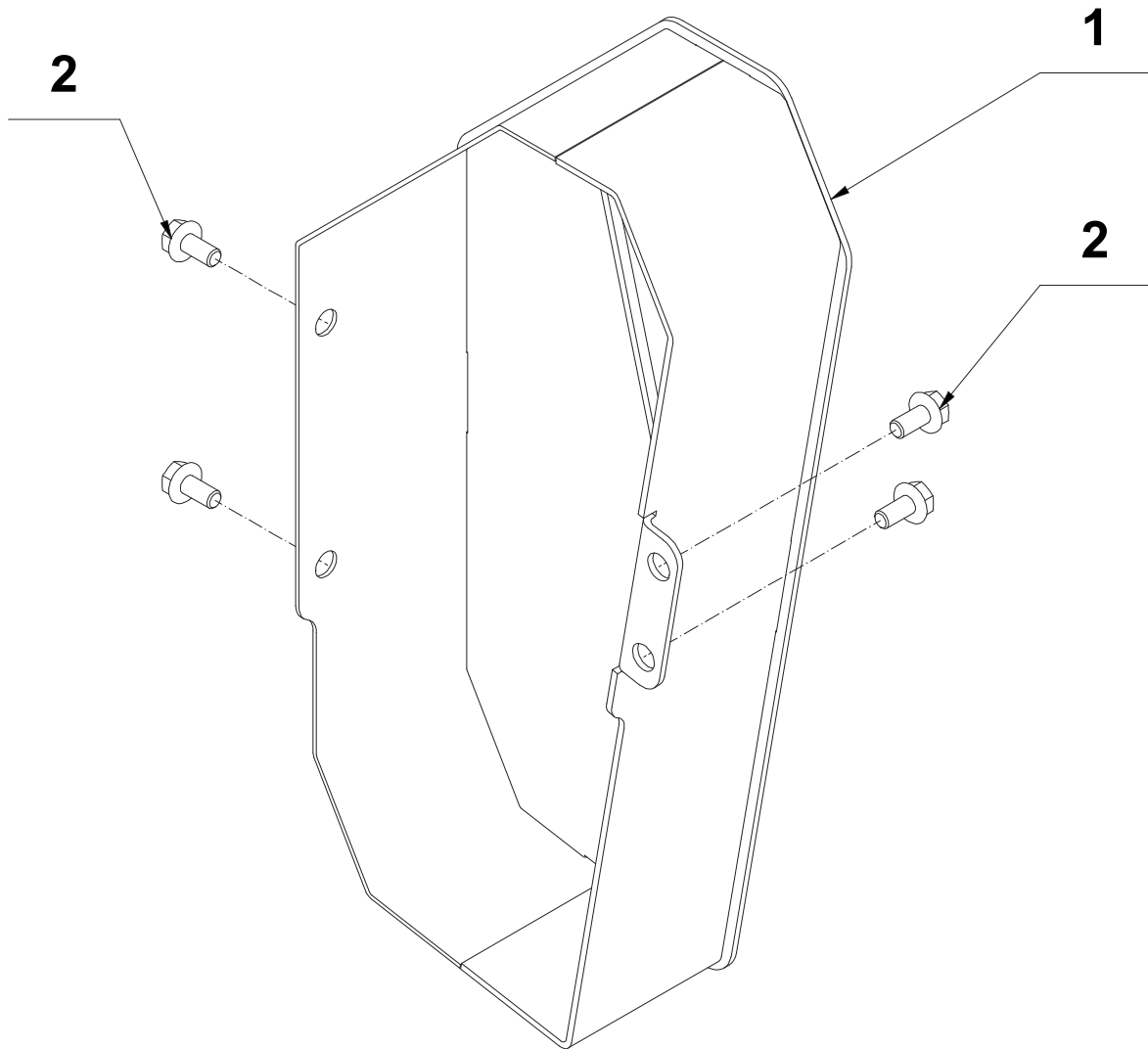

Floor saw
SEAFLOOR 500S

Position	Part number	Part Name	Quantity
1	SF500S31985A	COVER	1
2	SF500S2692108016	BOLT	4